

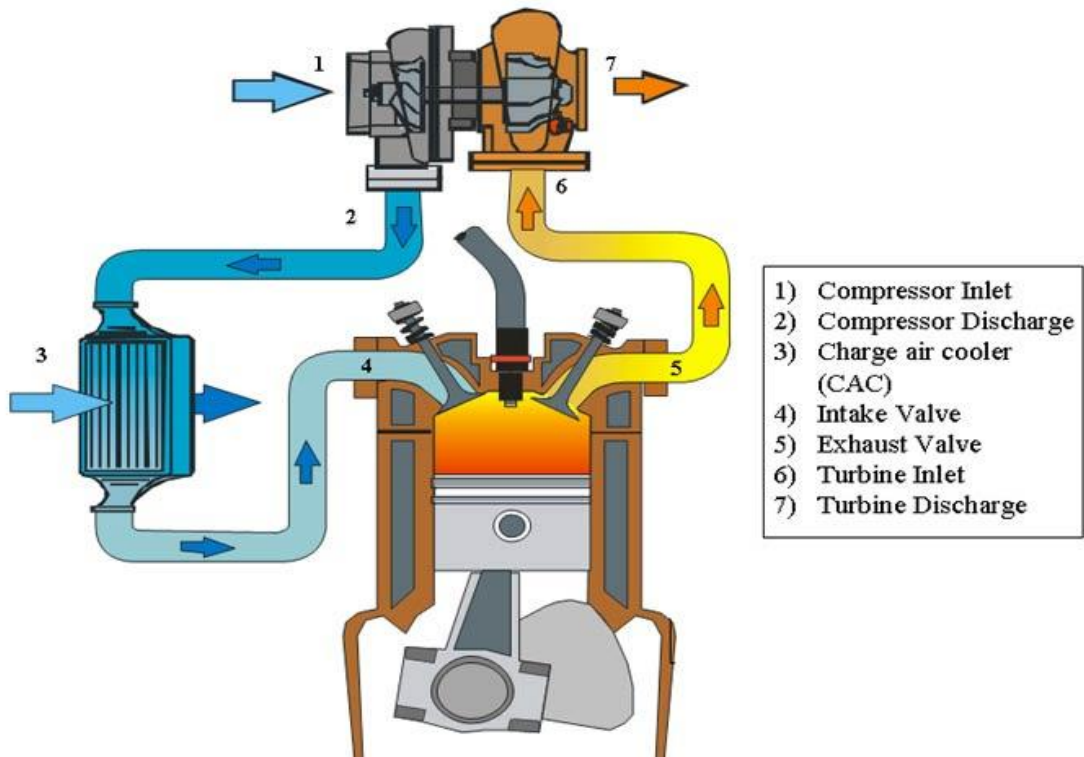

# **TURBOCHARGER FAILURE**

# **EGR SYSTEM**

## Typical Commercial Diesel Turbocharged Engine System

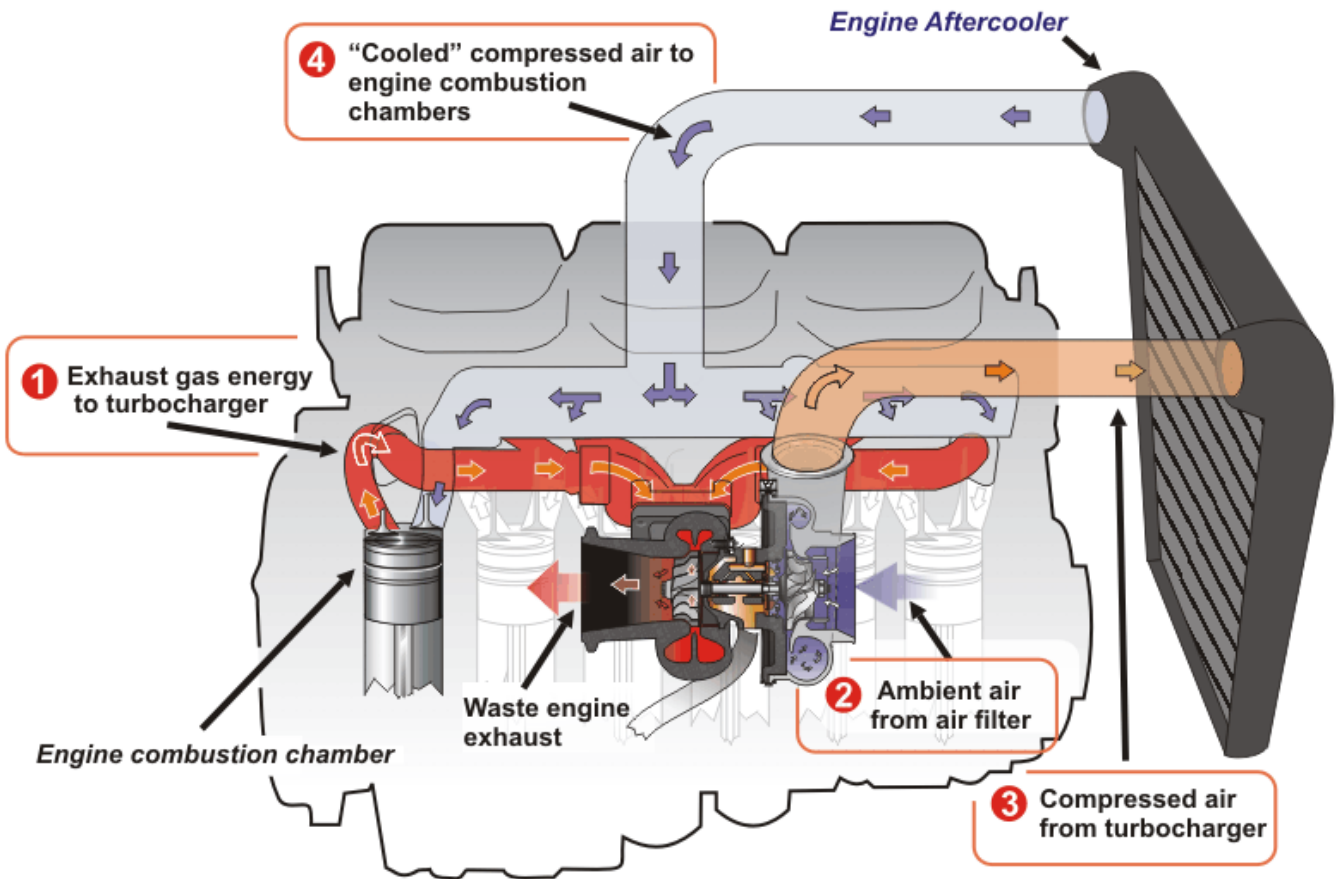

## FAILURES IN TURBOCHARGER DUE TO EGR SYSTEM

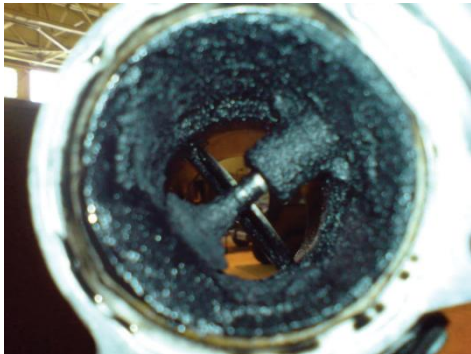

### Exhaust Gas Recirculation (EGR) Valve:

The EGR (Exhaust Gas Recirculation) valve recirculates a small amount of the exhaust gases back into the air intake system and lowering the maximum temperature of the burning fuel. The EGR valve ensures that the EGR system is disabled at idle speeds and at peak power.

The EGR valve can become stuck or choked with coke on some applications.

Non-functional EGR valve can create excessive carbon/soot at the turbine end of the turbocharger which can cause the Variable Turbine Geometry mechanism to get stuck / dysfunctional.

### Problems when EGR Valve remains closed:

- Erratic engine idling / unable to idle
- Engine operation poor when cold
- Fuel consumption is higher
- Poor performance / Power
- Engine warning fault light and/or fault code is activated

### Possible reasons for EGR Valve not Opening :

- EGR valve is stuck / glued up
- Air leaks on the vacuum side
- Vacuum connections are leaking, disconnected or incorrect
- Faulty electric switch pressure converter valve / Blow off valve not opening (in turbocharger).

### Possible reasons for EGR Valve not Closing :

- Heavy carbon / sludge deposits on tappet or valve
- EGR valve damaged through overheating, due to:
  - ❖ EGR Control Faulty
  - ❖ Exhaust back pressure high
  - ❖ Blow-off valve not opening (in turbocharger)
- Faulty sensor signal or Air flow meter
- Deposits inside the Intake pipe of the EGR system constricting it partly
- Oil leak from the turbocharger.



5

## Service Centers:

**Palakkad**  
17/550(9),KTV Tower,  
West Fort Road, Palakkad – 678 001  
Phone : 0491 – 3260808, 3208000

**Kochi**  
40/618, Bhagavathy Parambil Building,  
Near Federal Bank, Palarivattom, Kochi – 682 025  
Phone : 0848 -3114333

**Kozhikode**  
3/165-A,Nano Building,  
Major Santhosh Road, Behind Co-Op Urban Bank,  
Vandipetta, West Nadakkavu, Kozhikode – 673 011  
Phone : 0495 3104333

## Collection Centers:

**Kannur**  
EP III/178, EVES Arcade,  
Opposite Technical High School, Thottada, Kannur – 670 007  
Phone : 0497 – 3268785

**Thiruvananthapuram**  
TC 36/1090(9), Narayan Nilayam,  
Eanchakkal Junction, Vallakadavu P.O., Thiruvananthapuram – 695 008  
Phone : 0471 – 3198785

**Service Helpline : +91 491 3208000**  
**Technical Assistance : +91 93491 27136**

**Website : [www.paramountautozone.com](http://www.paramountautozone.com)**  
**[www.paramountgrp.net](http://www.paramountgrp.net)**

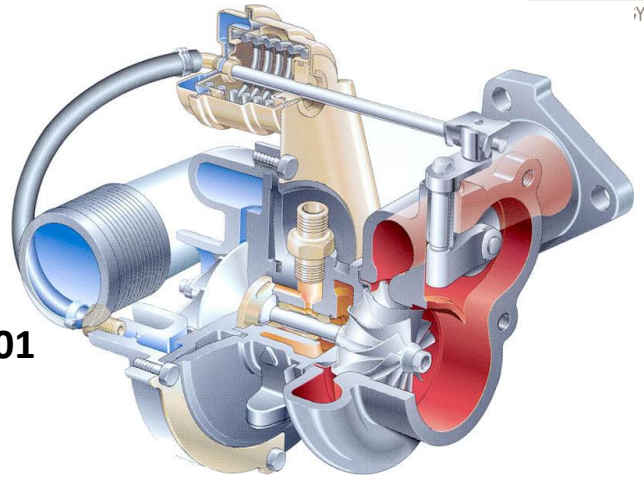



# Paramount auto **zone**

ISO 9001:2008 Certified Company



**Come to us for a cleaner and greener road to the future..**